

Drop-In

Drop-in refrigerated well, ventilated, 1 refrigerated shelf and 1 neutral shelf (2 GN)

ITEM # _____

MODEL # _____

NAME # _____

SIS # _____

AIA # _____

341050 (D13C2)

Drop-in refrigerated well, ventilated, with 1 refrigerated shelf and 1 neutral shelf (2 GN container capacity)

Short Form Specification

Item No.

Designed to be positioned in flush installation providing improved cleanability and suitable for modern design installations. Designed to serve: food in GN containers or food on plates/packages or bottles and cans thanks to adjustable bottom well. Suitable for GN 1/1 containers with a maximum height of 150 mm. Food introduced at the correct temperature maintains its core temperature according to Afnor Standards. Automatic defrosting guarantees evaporators clearance and efficient well cooling. Digital control with temperature display with precise adjustment (0,1°C). Fully compliant HACCP digital controls include visible alarms. Well equipped with adjustable bottom that can be set to 5 positions for each GN 1/1 section, independently one from the other to display different items with different heights. The temperature uniformity is guaranteed by powerful fans and high surface evaporator. Bottom part of well is removable for an easier access to the evaporator. Front grids and well bottom panels can be removed without the need of any tool for fast and effective cleaning. Well can be cleaned with a hose (after removing easily the fans). Includes an adjustable tempered glass shelf that can allocate dishes, a neutral shelf on the top and a bottom well divided in GN1/1 adjustable sections. Wells in 304 AISI stainless steel with rounded corners to facilitate cleaning operations. The well is also equipped with a drain hole. High-density expanded polyurethane foam with cyclopentane guarantees excellent well insulation to reduce energy dispersion. R290 refrigerant gas (GWP=3) to reduce environmental impact and increase cooling efficiency.

Main Features

- Bottom part of well is removable for an easier access to the evaporator.
- Suitable for GN 1/1 containers with a maximum height of 150 mm.
- Designed to be positioned in flush installation providing improved cleanability and suitable for modern design installations.
- Precise temperature control and setting at 0,1°C .
- As standard the product comes with digitally controlled thermostat which is in line of HACCP norms and provides visual alarm as a warning of the increasing or decreasing temperatures.
- Food introduced at the correct temperature maintains its core temperature according to Afnor Standards.
- Automatic defrosting guarantees evaporators clearance and efficient well cooling.
- Remote version is available.
- Designed to serve: food in GN containers or food on plates/packages or bottles and cans thanks to adjustable bottom well.
- Available drop-in dimensions: 2, 3, 4, 5 GN.
- Well equipped with adjustable bottom that can be set to 5 positions for each GN 1/1 section, independently one from the other to display different items with different heights.
- The temperature uniformity is guaranteed by powerful fans and high surface evaporator.
- Front grids and well bottom panels can be removed without the need of any tool for fast and effective cleaning.
- Well can be cleaned with a hose (after removing easily the fans).
- Includes an adjustable tempered glass shelf that can allocate dishes, a neutral shelf on the top and a bottom well divided in GN1/1 adjustable sections. Each section can be set to 5 positions independently one from the other to display different items with different heights.
- Ideal for displaying food and drinks with an elevation.
- CB and CE certified by a third party notified body.

Construction

- Well bottom is inclined to facilitate water drainage.
- Well in 304 AISI stainless steel with rounded corners to facilitate cleaning operations. The well is also equipped with a drain hole.
- Electronic control with temperature display.
- IPx2 water protection.

Sustainability

- Hydrocarbon refrigerant gas R290 for the lowest environmental impact (GWP=3) - CFC and HCFC free.
- High-density expanded polyurethane foam with cyclopentane guarantees excellent well insulation to reduce energy dispersion.



APPROVAL: _____

Rear side

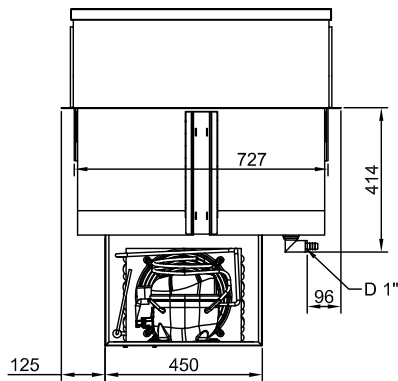

Side

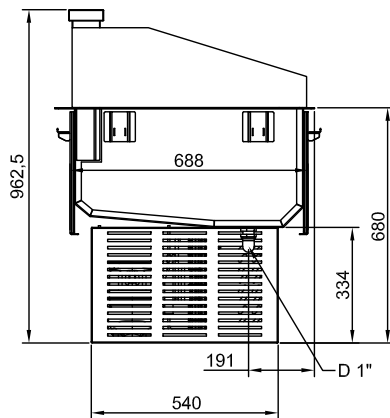

D = Drain
EI = Electrical inlet (power)

Top

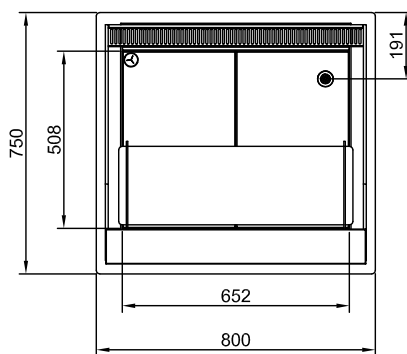

Electric

Supply voltage: 220-240 V/1N ph/50 Hz
Electrical power, max: 0.56 kW

Water:

Water drain outlet size: 1"

Key Information:

External dimensions,
Width: 800 mm
External dimensions,
Depth: 750 mm
External dimensions,
Height: 950 mm
Net weight: 69.7 kg
Shipping weight: 90 kg
Shipping height: 1070 mm
Shipping width: 790 mm
Shipping depth: 840 mm
Shipping volume: 0.71 m³
Set temperature: +4 / +8 °C

Refrigeration Data

Refrigerant type: R290

Sustainability

Noise level: 59 dBA

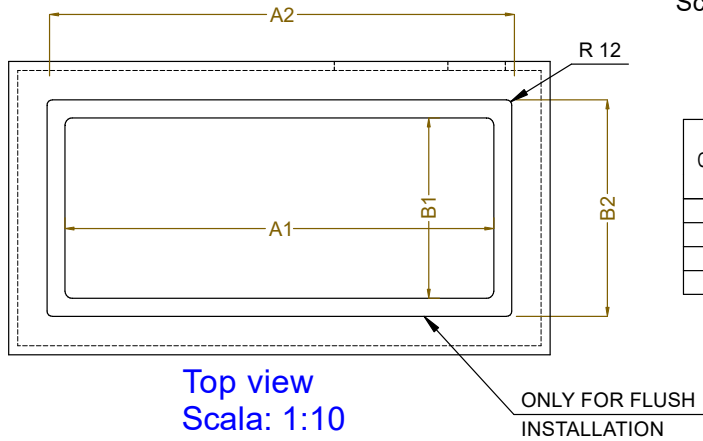
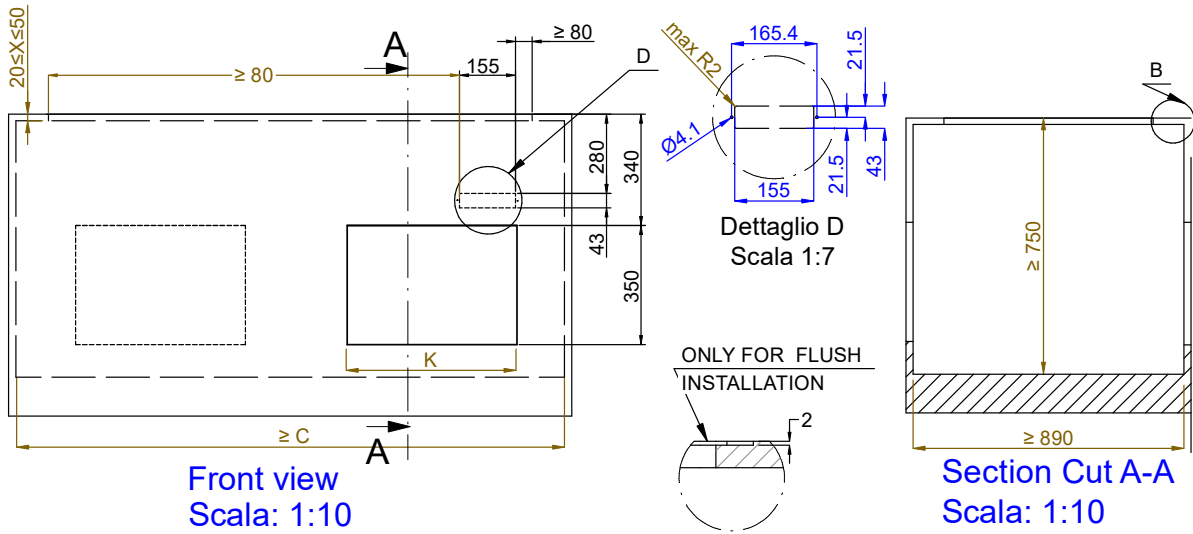

CAPACITY	CUTOUT		LOWERING FOR FLUSH INSTALLATION		C	K
	A1	B1	A2	B2		
2GN	740	710	804	754	920	470
3GN	1060		1124		1250	
4GN	1390		1454		1580	
5GN	1710		1174		1900	730

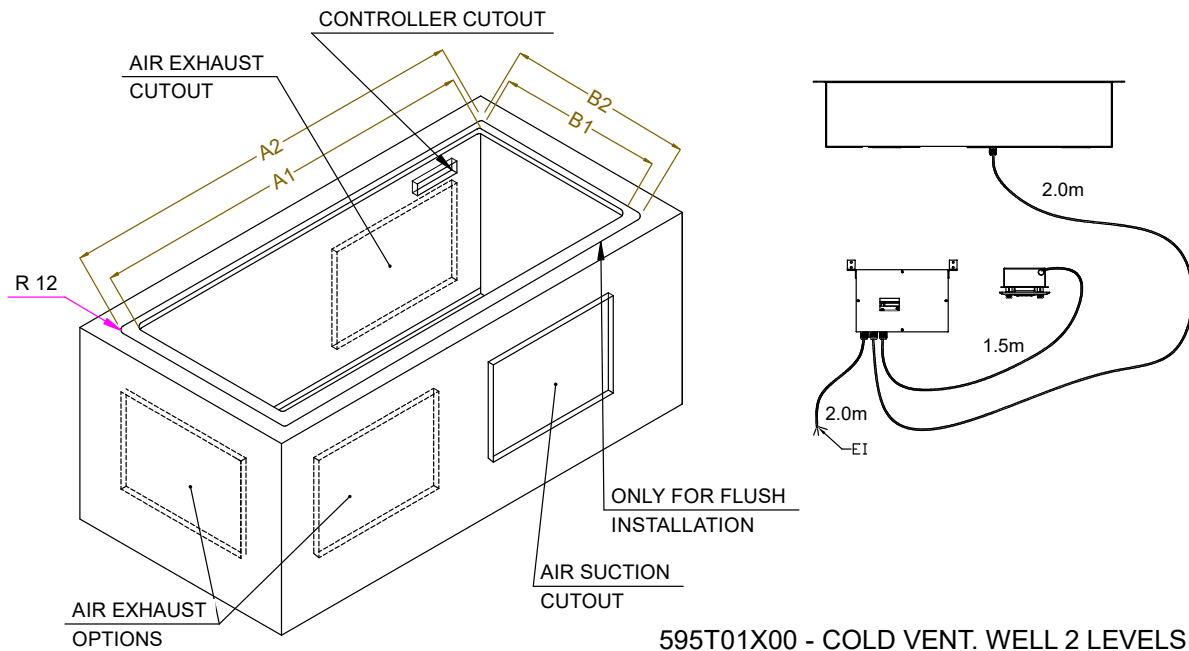

595T01X00 - COLD VENT. WELL 2 LEVELS